



DECSAI

Departamento de Ciencias de la Computación e I.A.

Universidad de Granada



Internet: Aplicaciones

Transmisión de datos y redes de ordenadores

Internet: Aplicaciones



La familia de protocolos TCP/IP

La capa de red en Internet

- El protocolo IP
- Protocolos auxiliares

La capa de transporte en Internet

- El protocolo TCP
- El protocolo UDP

La capa de aplicación en Internet

- El servicio de nombres DNS
- URLs [Uniform Resource Locators]
- Correo electrónico
- World Wide Web
- Aplicaciones multimedia



El servicio de nombres DNS



Dominios en Internet

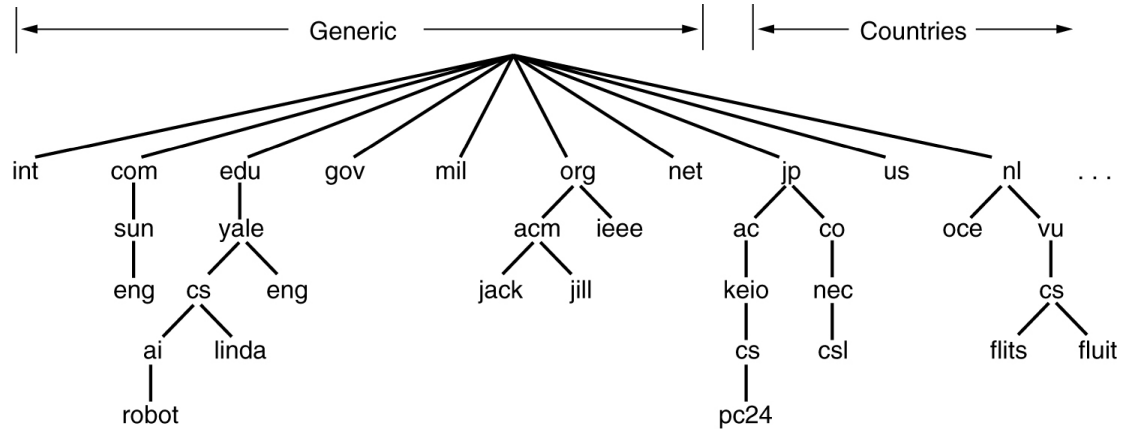

URL [Uniform Resource Locator]



Name	Used for	Example
http	Hypertext (HTML)	http://www.cs.vu.nl/~ast/
ftp	FTP	ftp://ftp.cs.vu.nl/pub/minix/README
file	Local file	file:///usr/suzanne/prog.c
news	Newsgroup	news:comp.os.minix
news	News article	news:AA0134223112@cs.utah.edu
gopher	Gopher	gopher://gopher.tc.umn.edu/11/Libraries
mailto	Sending e-mail	mailto:JohnUser@acm.org
telnet	Remote login	telnet://www.w3.org:80



Correo electrónico (e-mail)



Correo tradicional vs. Correo electrónico

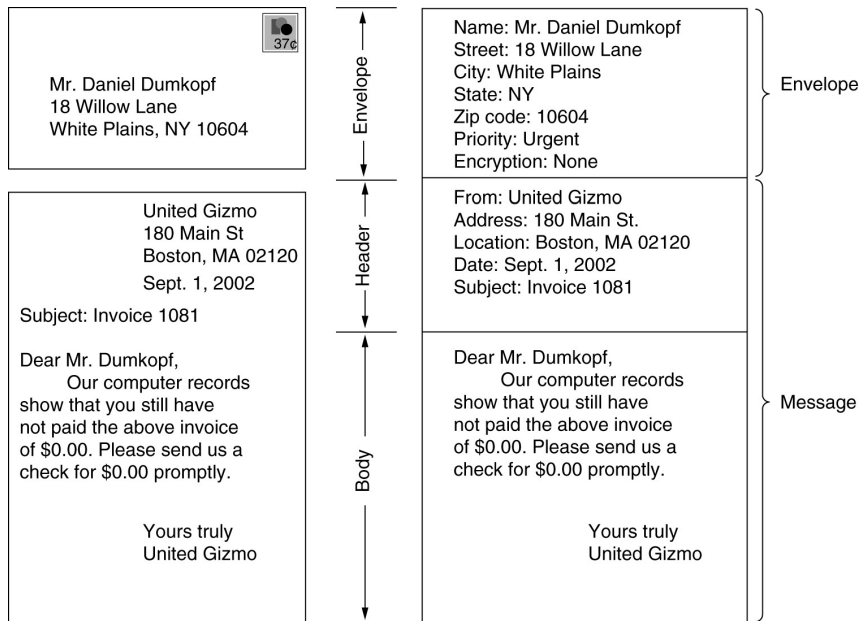

Correo electrónico (e-mail)



Cabecera de los mensajes de correo electrónico

RFC 822

Header	Meaning
To:	E-mail address(es) of primary recipient(s)
Cc:	E-mail address(es) of secondary recipient(s)
Bcc:	E-mail address(es) for blind carbon copies
From:	Person or people who created the message
Sender:	E-mail address of the actual sender
Received:	Line added by each transfer agent along the route
Return-Path:	Can be used to identify a path back to the sender

Header	Meaning
Date:	The date and time the message was sent
Reply-To:	E-mail address to which replies should be sent
Message-Id:	Unique number for referencing this message later
In-Reply-To:	Message-Id of the message to which this is a reply
References:	Other relevant Message-Ids
Keywords:	User-chosen keywords
Subject:	Short summary of the message for the one-line display



Correo electrónico (e-mail)



MIME [Multi-purpose Internet Mail Extensions]

- Mensajes en distintos idiomas: tildes, distintos alfabetos...
- Mensajes con ficheros adjuntos (audio, vídeo...)

Cabeceras MIME

Header	Meaning
MIME-Version:	Identifies the MIME version
Content-Description:	Human-readable string telling what is in the message
Content-Id:	Unique identifier
Content-Transfer-Encoding:	How the body is wrapped for transmission
Content-Type:	Type and format of the content



Correo electrónico (e-mail)



MIME [Multi-purpose Internet Mail Extensions]

RFC 2045: Tipos y subtipos MIME

Type	Subtype	Description
Text	Plain	Unformatted text
	Enriched	Text including simple formatting commands
Image	Gif	Still picture in GIF format
	Jpeg	Still picture in JPEG format
Audio	Basic	Audible sound
Video	Mpeg	Movie in MPEG format
Application	Octet-stream	An uninterpreted byte sequence
	Postscript	A printable document in PostScript
Message	Rfc822	A MIME RFC 822 message
	Partial	Message has been split for transmission
	External-body	Message itself must be fetched over the net
Multipart	Mixed	Independent parts in the specified order
	Alternative	Same message in different formats
	Parallel	Parts must be viewed simultaneously
	Digest	Each part is a complete RFC 822 message



Correo electrónico (e-mail)



MIME [Multi-purpose Internet Mail Extensions]

Ejemplo

From: elinor@abcd.com
To: carolyn@xyz.com
MIME-Version: 1.0
Message-Id: <0704760941.AA00747@abcd.com>
Content-Type: multipart/alternative; boundary=qwertyuiopasdfghjklzxcvbnm
Subject: Earth orbits sun integral number of times

This is the preamble. The user agent ignores it. Have a nice day.

--qwertyuiopasdfghjklzxcvbnm
Content-Type: text/enriched

Happy birthday to you
Happy birthday to you
Happy birthday dear <bold> Carolyn </bold>
Happy birthday to you

--qwertyuiopasdfghjklzxcvbnm
Content-Type: message/external-body;
access-type="anon-ftp";
site="bicycle.abcd.com";
directory="pub";
name="birthday.snd"

content-type: audio/basic
content-transfer-encoding: base64
--qwertyuiopasdfghjklzxcvbnm--



Correo electrónico (e-mail)



Netiquette (o "netiqueta")

<http://es.wikipedia.org/wiki/Netiqueta>

Smileys

Smiley	Meaning	Smiley	Meaning	Smiley	Meaning
:~)	I'm happy	=!:-)	Abe Lincoln	:+)	Big nose
:-(I'm sad/angry	=):-)	Uncle Sam	:~))	Double chin
:~	I'm apathetic	*<:-)	Santa Claus	:~{)	Mustache
:~)	I'm winking	<:-)	Dunce	#:-)	Matted hair
:~(O)	I'm yelling	(-:	Australian	8-)	Wears glasses
:~(*)	I'm vomiting	:~)X	Man with bowtie	C:-)	Large brain



Correo electrónico (e-mail)



Transferencia de mensajes de correo electrónico

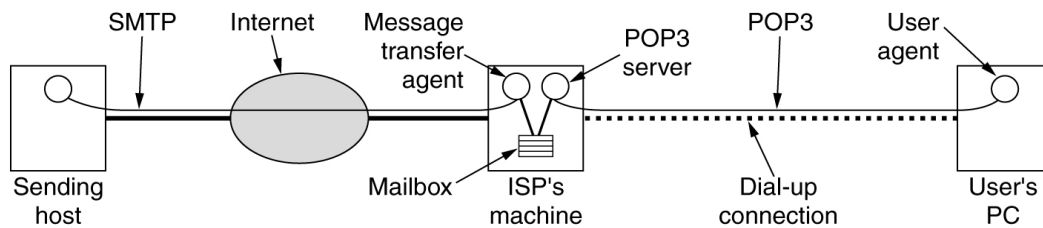
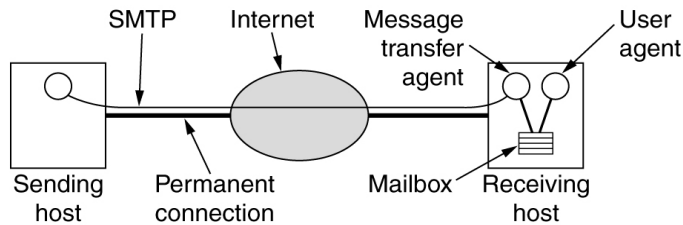

Correo electrónico (e-mail)



SMTP [Simple Mail Transfer Protocol]

RFC 821

```
S: 220 xyz.com SMTP service ready
C: HELO abcd.com
S: 250 xyz.com says hello to abcd.com
C: MAIL FROM: <elinor@abcd.com>
S: 250 sender ok
C: RCPT TO: <carolyn@xyz.com>
S: 250 recipient ok
C: DATA
S: 354 Send mail; end with "." on a line by itself
C: From: elinor@abcd.com
C: To: carolyn@xyz.com
C: MIME-Version: 1.0
C: Message-Id: <0704760941.AA00747@abcd.com>
C: Content-Type: multipart/alternative; boundary=qwertyuiopasdfghijklzxcvbnm
C: Subject: Earth orbits sun integral number of times
C:
C: This is the preamble. The user agent ignores it. Have a nice day.
C:
C: --qwertyuiopasdfghijklzxcvbnm
C: Content-Type: text/enriched
C:
C: Happy birthday to you
C: Happy birthday to you
C: Happy birthday dear <bold> Carolyn </bold>
C: Happy birthday to you
C:
C: --qwertyuiopasdfghijklzxcvbnm
C: Content-Type: message/external-body;
C: access-type="anon-ftp";
C: site="bicycle.abcd.com";
C: directory="pub";
C: name="birthday.snd"
C:
C: content-type: audio/basic
C: content-transfer-encoding: base64
C: --qwertyuiopasdfghijklzxcvbnm
C: .
S: 250 message accepted
C: QUIT
S: 221 xyz.com closing connection
```



Correo electrónico (e-mail)



POP3 [Post Office Protocol – Version 3] RFC 1939

```
S: +OK POP3 server ready
C: USER carolyn
S: +OK
C: PASS vegetables
S: +OK login successful
C: LIST
S: 1 2505
S: 2 14302
S: 3 8122
S: .
C: RETR 1
S: (sends message 1)
C: DELE 1
C: RETR 2
S: (sends message 2)
C: DELE 2
C: RETR 3
S: (sends message 3)
C: DELE 3
C: QUIT
S: +OK POP3 server disconnecting
```



Correo electrónico (e-mail)



POP3 vs. IMAP

Feature	POP3	IMAP
Where is protocol defined?	RFC 1939	RFC 2060
Which TCP port is used?	110	143
Where is e-mail stored?	User's PC	Server
Where is e-mail read?	Off-line	On-line
Connect time required?	Little	Much
Use of server resources?	Minimal	Extensive
Multiple mailboxes?	No	Yes
Who backs up mailboxes?	User	ISP
Good for mobile users?	No	Yes
User control over downloading?	Little	Great
Partial message downloads?	No	Yes
Are disk quotas a problem?	No	Could be in time
Simple to implement?	Yes	No
Widespread support?	Yes	Growing



World Wide Web



Arquitectura

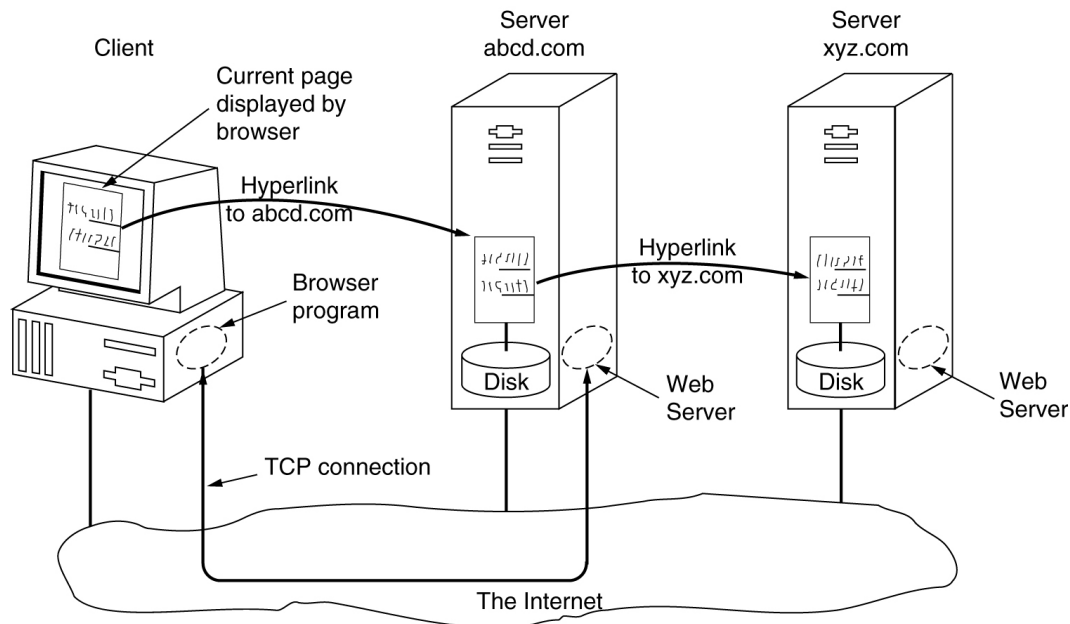

14

World Wide Web



Cookies

Domain	Path	Content	Expires	Secure
toms-casino.com	/	CustomerID=497793521	15-10-02 17:00	Yes
joes-store.com	/	Cart=1-00501;1-07031;2-13721	11-10-02 14:22	No
aportal.com	/	Prefs=Stk:SUNW+ORCL;Spt:Jets	31-12-10 23:59	No
sneaky.com	/	UserID=3627239101	31-12-12 23:59	No

El protocolo TCP no mantiene información acerca de las sesiones, por lo cual se idearon las cookies, que almacenan en el cliente información relativa a la sesión del usuario (con los consiguientes problemas de seguridad que esto puede conllevar).



15



HTML [HyperText Markup Language]

Algunas etiquetas...

Tag	Description
<html> ... </html>	Declares the Web page to be written in HTML
<head> ... </head>	Delimits the page's head
<title> ... </title>	Defines the title (not displayed on the page)
<body> ... </body>	Delimits the page's body
<h <i>n</i> > ... </h <i>n</i> >	Delimits a level <i>n</i> heading
 ... 	Set ... in boldface
<i> ... </i>	Set ... in italics
<center> ... </center>	Center ... on the page horizontally
 ... 	Brackets an unordered (bulleted) list
 ... 	Brackets a numbered list
	Starts a list item (there is no)
 	Forces a line break here
<p>	Starts a paragraph
<hr>	Inserts a Horizontal rule
	Displays an image here
 ... 	Defines a hyperlink



HTML [HyperText Markup Language]

Versiones

- HTML 1.0 (1991)
CERN, diseño inicial basado en SGML: sólo 20 etiquetas.
- HTML 2.0 (1995)
Estándar IETF: Imágenes, formularios e "imagemaps".
- HTML 3.2 (1997)
Recomendación W3C: Tablas (eliminó fórmulas matemáticas).
- HTML 4.01 (1999)
HTML dinámico.
- XHTML (2000)
Sintaxis XML [eXtensible Markup Language].



World Wide Web



HTML [HyperText Markup Language]

Ejemplo

```
<html>
<head><title> AMALGAMATED WIDGET, INC. </title> </head>
<body> <h1> Welcome to AWI's Home Page</h1>
 <br>
We are so happy that you have chosen to visit <b> Amalgamated Widget's </b>
home page. We hope <i> you </i> will find all the information you need here.
<p>Below we have links to information about our many fine products.
You can order electronically (by WWW), by telephone, or by fax. </p>
<hr>
<h2> Product information </h2>
<ul>
<li> <a href="http://widget.com/products/big"> Big widgets </a>
<li> <a href="http://widget.com/products/little"> Little widgets </a>
</ul>
<h2> Telephone numbers</h2>
<ul>
<li> By telephone: 1-800-WIDGETS
<li> By fax: 1-415-765-4321
</ul>
</body>
</html>
```

Welcome to AWI's Home Page



We are so happy that you have chosen to visit **Amalgamated Widget's** home page. We hope you will find all the information you need here.

Below we have links to information about our many fine products. You can order electronically (by WWW), by telephone, or by FAX.

Product Information

- Big widgets
- Little widgets

Telephone numbers

- 1-800-WIDGETS
- 1-415-765-4321



World Wide Web



HTML [HyperText Markup Language]

Ejemplo con formulario

```
<html>
<head> <title> AWI CUSTOMER ORDERING FORM </title> </head>
<body>
<h1> Widget Order Form </h1>
<form ACTION="http://widget.com/cgi-bin/widgetorder" method=POST>
<p> Name <input name="customer" size=46> </p>
<p> Street Address <input name="address" size=40> </p>
<p> City <input name="city" size=20> State <input name="state" size=4>
Country <input name="country" size=10> </p>
<p> Credit card # <input name="cardno" size=10>
Expires <input name="expires" size=4>
M/C <input name="cc" type=radio value="mastercard">
VISA <input name="cc" type=radio value="visacard"> </p>
<p> Widget size Big <input name="product" type=radio value="expensive">
Little <input name="product" type=radio value="cheap">
Ship by express courier <input name="express" type=checkbox> </p>
<p><input type=submit value="submit order"> </p>
Thank you for ordering an AWI widget, the best widget money can buy!
</form>
</body>
</html>
```

Widget Order Form

Name

Street address

City State Country

Credit card # Expires M/C Visa

Widget size Big Little Ship by express courier

Thank you for ordering an AWI widget, the best widget money can buy!

Envío de los datos al servidor:

customer=John+Doe&address=100+Main+St.&city=White+Plains&
state=NY&country=USA&cardno=1234567890&expires=6/98&cc=mastercard&
product=cheap&express=on





Hojas de estilo CSS [Cascading StyleSheets]

```
p, li, td
{
  text-align: justify;
}

a
{
  text-decoration: none;
}

a:hover
{
  color: #009999;
}
```

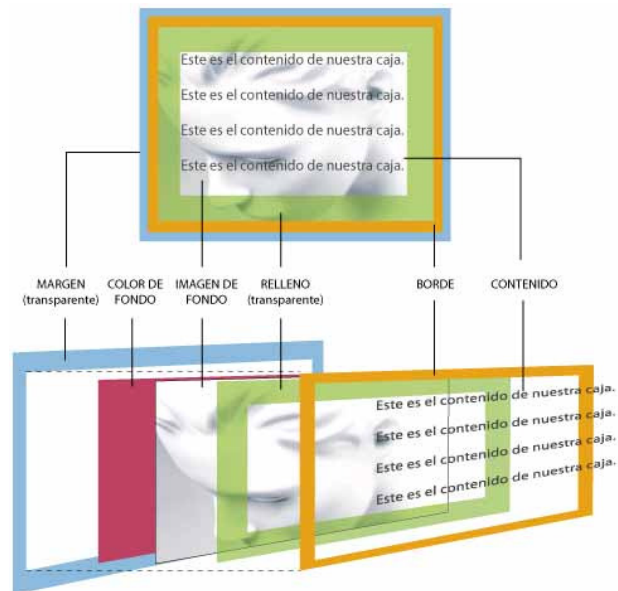

Documentos XML [eXtensible Markup Language]

```
<?xml version="1.0" ?>
<?xml-stylesheet type="text/xsl" href="b5.xsl"?>
<book_list>
  <book>
    <title> Computer Networks, 4/e </title>
    <author> Andrew S. Tanenbaum </author>
    <year> 2003 </year>
  </book>
  <book>
    <title> Modern Operating Systems, 2/e </title>
    <author> Andrew S. Tanenbaum </author>
    <year> 2001 </year>
  </book>
  <book>
    <title> Structured Computer Organization, 4/e </title>
    <author> Andrew S. Tanenbaum </author>
    <year> 1999 </year>
  </book>
</book_list>
```





Hojas de estilo XSL [eXtensible Stylesheet Language]

```
<?xml version='1.0'?>
<xsl:stylesheet xmlns:xsl="http://www.w3.org/1999/XSL/Transform" version="1.0">
<xsl:template match="/">

<html>
<body>
<table border="2">
  <tr>
    <th> Title</th>
    <th> Author</th>
    <th> Year </th>
  </tr>

  <xsl:for-each select="book_list/book">
    <tr>
      <td> <xsl:value-of select="title"/> </td>
      <td> <xsl:value-of select="author"/> </td>
      <td> <xsl:value-of select="year"/> </td>
    </tr>
  </xsl:for-each>
</table>

</body>
</html>
</xsl:template>
</xsl:stylesheet>
```



Páginas web dinámicas

■ En el servidor

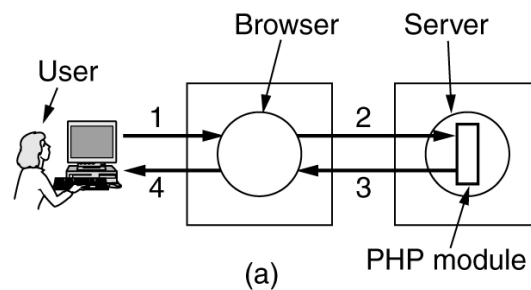

■ En el cliente

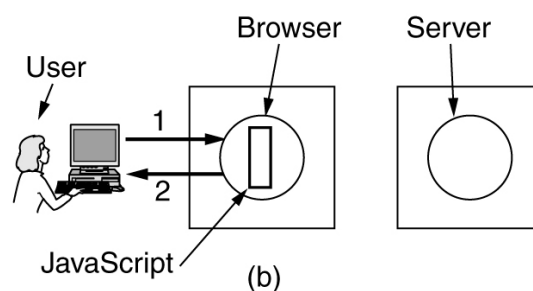

World Wide Web



En el servidor:

CGI [Common Gateway Interface]

p.ej. Perl, PHP, ASP.NET, JSP, servlets...

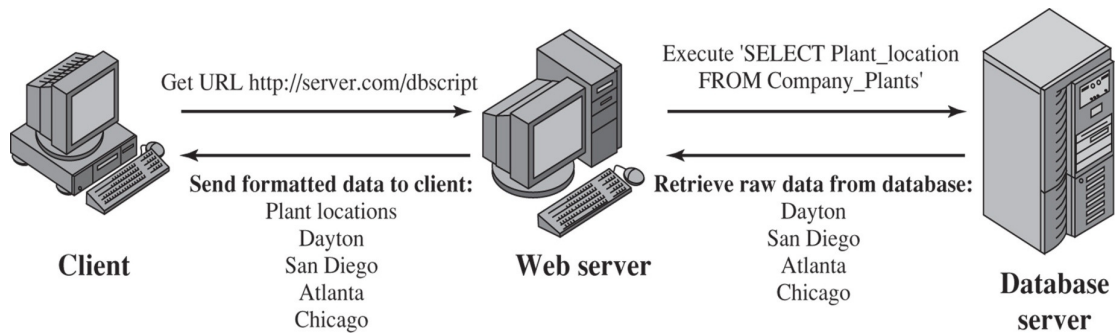

24

World Wide Web



En el cliente:

HTML dinámico

p.ej. JavaScript

```
<head>
<script language="javascript" type="text/javascript">
function response(test form) {
  var person = test form.name.value;
  var years = eval(test form.age.value) + 1;
  document.open();
  document.writeln("<html> <body>");
  document.writeln("Hello " + person + ".<br>");
  document.writeln("Prediction: next year you will be " + years + ".");
  document.writeln("</body> </html>");
  document.close();
}
</script>
</head>
<body>
<form>
Please enter your name: <input type="text" name="name">
<p>
Please enter your age: <input type="text" name="age">
<p>
<input type="button" value="submit" onclick="response(this.form)">
</form>
</body>
</html>
```



25



El protocolo HTTP [Hypertext Transfer Protocol]

Métodos (tipos de solicitudes)

Method	Description
GET	Request to read a Web page
HEAD	Request to read a Web page's header
PUT	Request to store a Web page
POST	Append to a named resource (e.g., a Web page)
DELETE	Remove the Web page
TRACE	Echo the incoming request
CONNECT	Reserved for future use
OPTIONS	Query certain options

Códigos de estado (respuestas a una solicitud HTTP)

Code	Meaning	Examples
1xx	Information	100 = server agrees to handle client's request
2xx	Success	200 = request succeeded; 204 = no content present
3xx	Redirection	301 = page moved; 304 = cached page still valid
4xx	Client error	403 = forbidden page; 404 = page not found
5xx	Server error	500 = internal server error; 503 = try again later



El protocolo HTTP [Hypertext Transfer Protocol]

Cabeceras de los mensajes HTTP

Header	Type	Contents
User-Agent	Request	Information about the browser and its platform
Accept	Request	The type of pages the client can handle
Accept-Charset	Request	The character sets that are acceptable to the client
Accept-Encoding	Request	The page encodings the client can handle
Accept-Language	Request	The natural languages the client can handle
Host	Request	The server's DNS name
Authorization	Request	A list of the client's credentials
Cookie	Request	Sends a previously set cookie back to the server
Date	Both	Date and time the message was sent
Upgrade	Both	The protocol the sender wants to switch to
Server	Response	Information about the server
Content-Encoding	Response	How the content is encoded (e.g., gzip)
Content-Language	Response	The natural language used in the page
Content-Length	Response	The page's length in bytes
Content-Type	Response	The page's MIME type
Last-Modified	Response	Time and date the page was last changed
Location	Response	A command to the client to send its request elsewhere
Accept-Ranges	Response	The server will accept byte range requests
Set-Cookie	Response	The server wants the client to save a cookie



Aplicaciones multimedia



Ejemplos: Radio, Telefonía IP, videoconferencias...

Streaming

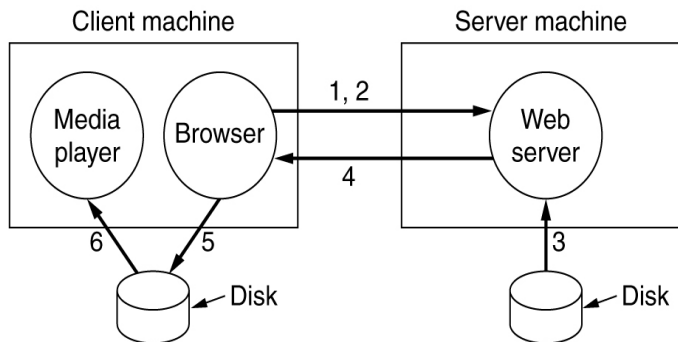

1. Establish TCP connection
2. Send HTTP GET request
3. Server gets file from disk
4. File sent back
5. Browser writes file to disk
6. Media player fetches file block by block and plays it



Aplicaciones multimedia



El reproductor multimedia almacena muestras temporalmente en un buffer para después reproducirlas uniformemente (sin "jitter"):

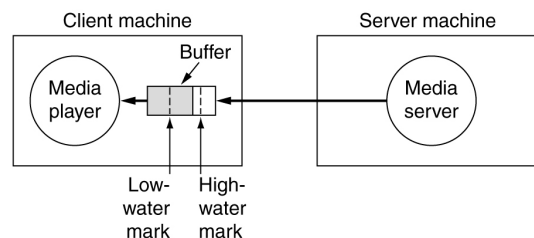

Cuando los paquetes envían muestras alternas, la pérdida de paquetes sólo ocasiona una pérdida en la calidad de la transmisión:

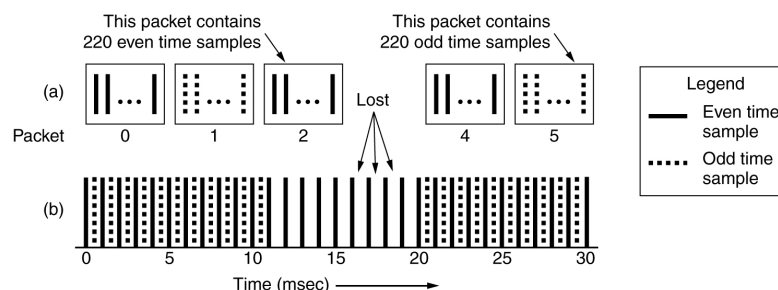

Aplicaciones multimedia



Telefonía IP = VoIP [Voice over IP] = H.323 Estándar ITU

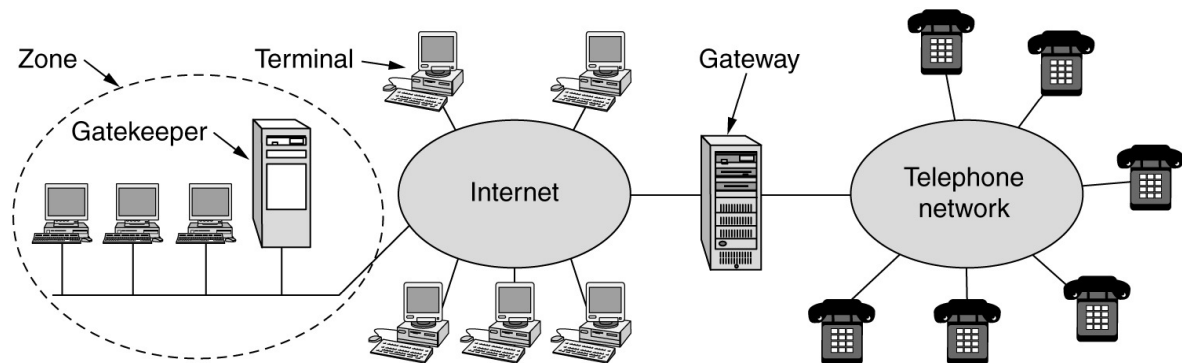

Aplicaciones multimedia



Telefonía IP Protocolos H.323

Speech	Control			
G.7xx	RTCP	H.225 (RAS)	Q.931 (Call signaling)	H.245 (Call control)
RTP				
UDP			TCP	
IP				
Data link protocol				
Physical layer protocol				



Aplicaciones multimedia



Telefonía IP

Canales lógicos empleados en una llamada H.323

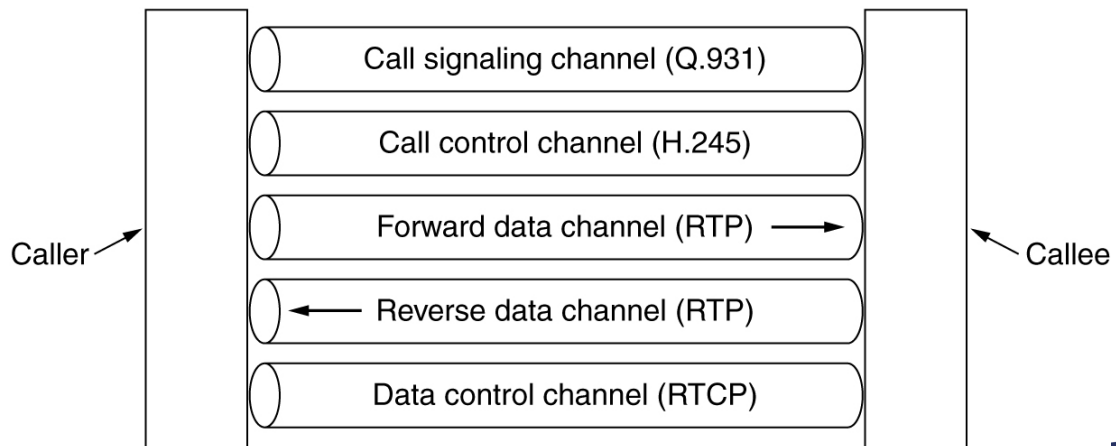

Aplicaciones multimedia



SIP [Session Initiation Protocol]

Estándar IETF

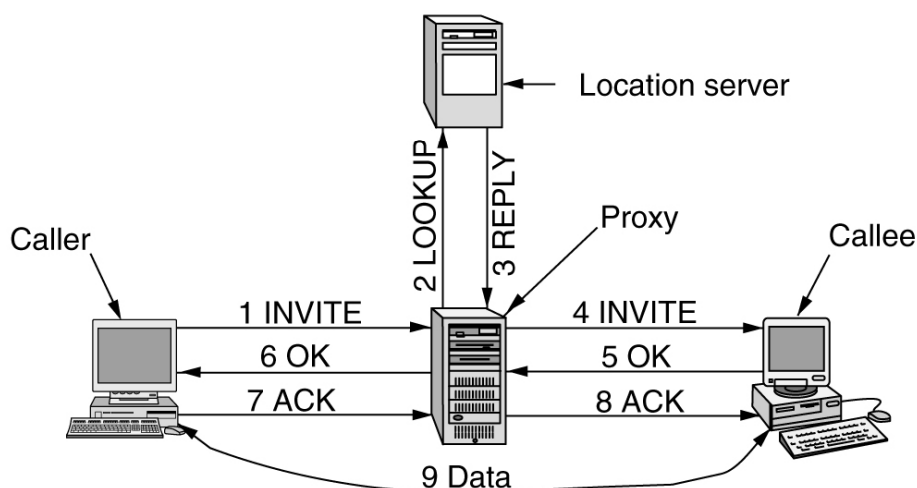

Aplicaciones multimedia



Item	H.323	SIP
Designed by	ITU	IETF
Compatibility with PSTN	Yes	Largely
Compatibility with Internet	No	Yes
Architecture	Monolithic	Modular
Completeness	Full protocol stack	SIP just handles setup
Parameter negotiation	Yes	Yes
Call signaling	Q.931 over TCP	SIP over TCP or UDP
Message format	Binary	ASCII
Media transport	RTP/RTCP	RTP/RTCP
Multiparty calls	Yes	Yes
Multimedia conferences	Yes	No
Addressing	Host or telephone number	URL
Call termination	Explicit or TCP release	Explicit or timeout
Instant messaging	No	Yes
Encryption	Yes	Yes
Size of standards	1400 pages	250 pages
Implementation	Large and complex	Moderate
Status	Widely deployed	Up and coming



Aplicaciones multimedia



VoD: Video on Demand

[Vídeo bajo demanda]

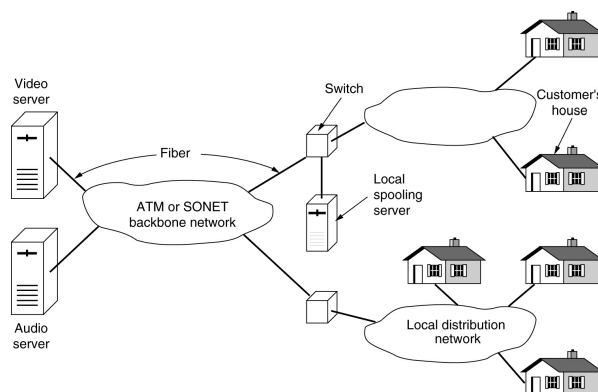

p.ej. "Triple play services" = Internet + TV + Teléfono



Apéndice Compresión de vídeo

Imágenes rasterizadas = Mapas de bits

Matrices bidimensionales de píxeles

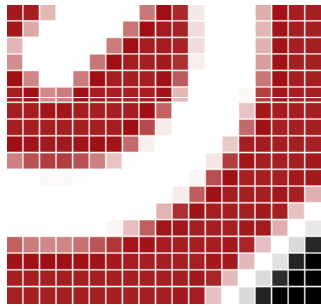

vs. gráficos vectoriales

(representan una imagen a través del uso de objetos geométricos como curvas de Bézier y polígonos, no del simple almacenamiento del color de cada píxel)



Apéndice Compresión de vídeo

Técnicas de compresión de imágenes

■ Compresión sin pérdidas

Se conserva íntegramente la imagen original

- GIF [Graphics Interchange Format]
- PNG [Portable Network Graphics]

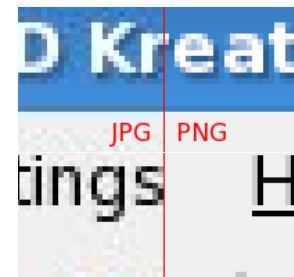

■ Compresión con pérdidas

Imposible reconstruir la imagen original

- JPEG [Joint Photographic Experts Group]



Apéndice Compresión de vídeo

Compresión de imágenes con JPEG

1. División de la imagen en bloques

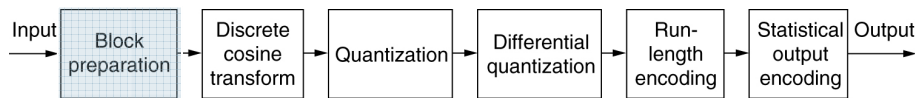
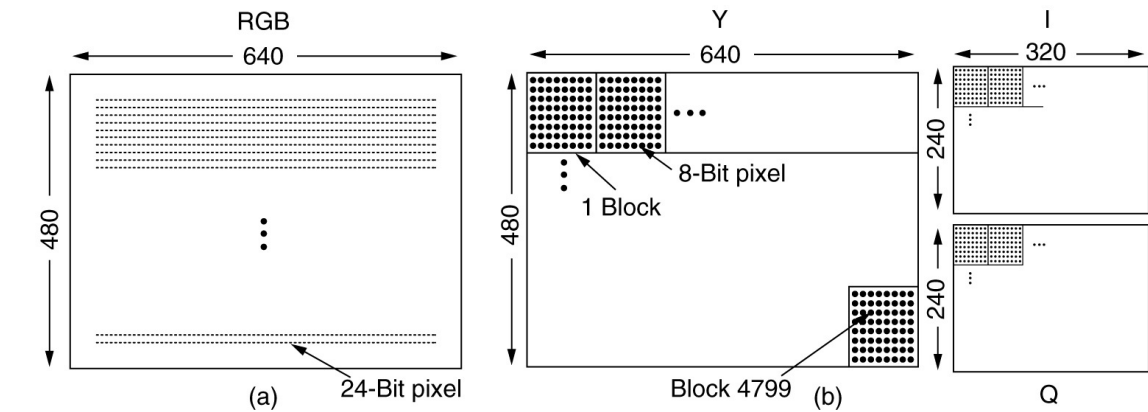

38

Apéndice Compresión de vídeo

Compresión de imágenes con JPEG

2. Transformada de coseno discreta (DCT)

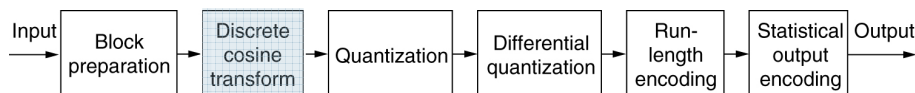
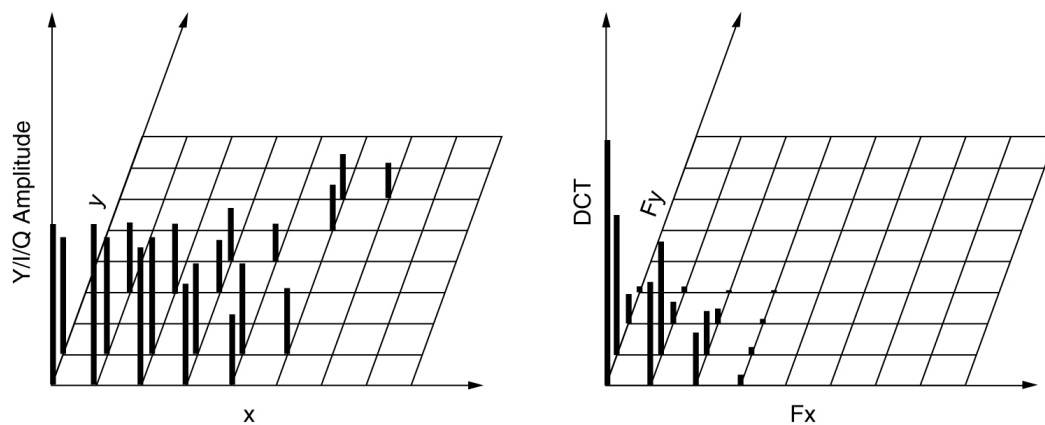

39

Apéndice Compresión de vídeo

Compresión de imágenes con JPEG

3. Cuantización de los coeficientes

DCT Coefficients								Quantization table								Quantized coefficients							
150	80	40	14	4	2	1	0	1	1	2	4	8	16	32	64	150	80	20	4	1	0	0	0
92	75	36	10	6	1	0	0	1	1	2	4	8	16	32	64	92	75	18	3	1	0	0	0
52	38	26	8	7	4	0	0	2	2	2	4	8	16	32	64	26	19	13	2	1	0	0	0
12	8	6	4	2	1	0	0	4	4	4	4	8	16	32	64	3	2	2	1	0	0	0	0
4	3	2	0	0	0	0	0	8	8	8	8	8	16	32	64	1	0	0	0	0	0	0	0
2	2	1	1	0	0	0	0	16	16	16	16	16	16	32	64	0	0	0	0	0	0	0	0
1	1	0	0	0	0	0	0	32	32	32	32	32	32	32	64	0	0	0	0	0	0	0	0
0	0	0	0	0	0	0	0	64	64	64	64	64	64	64	64	0	0	0	0	0	0	0	0

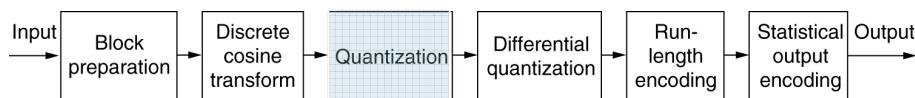

Apéndice Compresión de vídeo

Compresión de imágenes con JPEG

4. Ordenación de los coeficientes

150	80	20	4	1	0	0	0
92	75	18	3	1	0	0	0
26	19	13	2	1	0	0	0
3	2	2	1	0	0	0	0
1	0	0	0	0	0	0	0
0	0	0	0	0	0	0	0
0	0	0	0	0	0	0	0
0	0	0	0	0	0	0	0

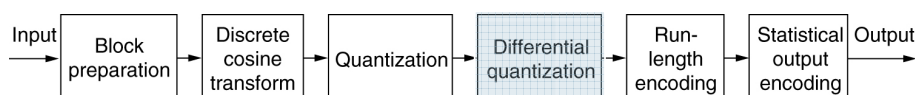

Apéndice Compresión de vídeo

Televisión

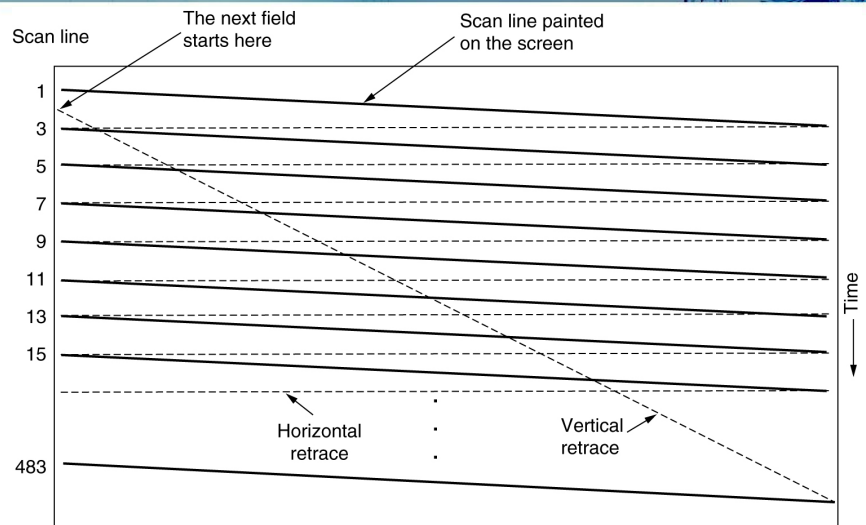

- PAL [Phase Alternating Line]
Usado en Europa, 576 líneas, 25 fotogramas por segundo.
- NTSC [National Television Standards Committee]
Usado en Estados Unidos y Japón, 480 líneas, 29.97 fps.



Apéndice Compresión de vídeo

Compresión de vídeo con MPEG

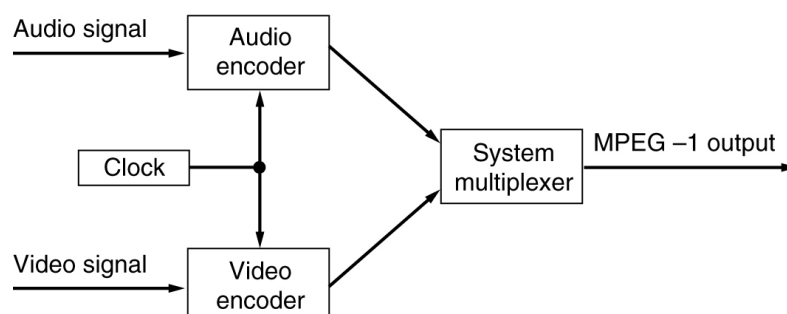
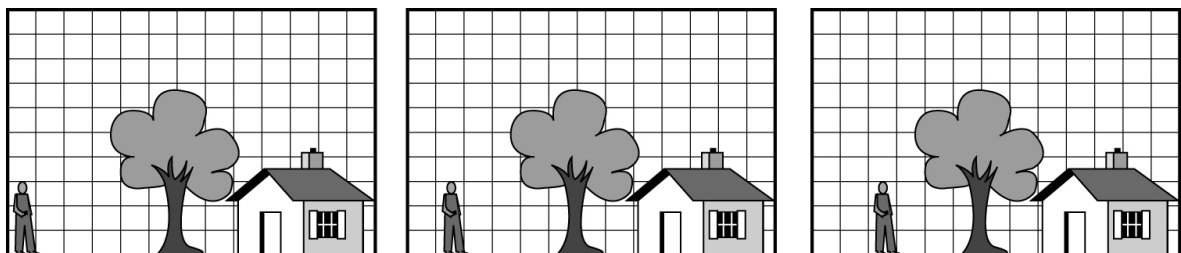

Apéndice Compresión de vídeo

Formato	Algoritmo de compresión	Resolución	Calidad equivalente
VideoCD	MPEG-1	352x288	VHS
SuperVideoCD	MPEG-2	480x576	Entre VHS y DVD
DVD TDT	MPEG-2	720x576	DVD
DivX, XviD...	MPEG-4 parte 2	720x576	Como un DVD (pero en CD)
H.264/AVC Blu-ray	MPEG-4 parte 10	1920x1080	HDTV = 1080i (entrelazado) FullHD = 1080p (progresivo)
DV	Ninguno	720x576	Cámara de vídeo digital



Bibliografía

- Jesús E. Díaz Verdejo; Juan Manuel López Soler & Pedro García Teodoro: **Transmisión de datos y redes de computadores.**
Prentice-Hall, 2003. ISBN 84-205-3919-8.
- Douglas E. Comer:
Computer networks and Internets.
Prentice-Hall, 2008 [5ª edición]. ISBN 0-13-606127-3.
- William Stallings:
Comunicaciones y redes de computadores.
Prentice-Hall, 2004 [7ª edición]. ISBN 84-205-4110-9.
- Andrew S. Tanenbaum:
Redes de computadoras.
Prentice-Hall, 2003 [4ª edición]. ISBN 970-260-162-2.

